

Activities of the T.I.C. - Seventh General Assembly

The Seventh General Assembly of the T.I.C. was held in Winnipeg, Manitoba, Canada in the Winnipeg Inn on Wednesday 4 May 1977. Of the twenty-two members, all were present or represented by proxy. In addition, six candidate members were represented. Total attendance was forty-six with many guests from both member companies, and other interested agencies.

The General Assembly elected seven new members. Committee reports included a statement of the satisfactory financial position of the T.I.C., and requests for articles about each member company to be printed in the « Bulletin ». The Assembly voted to proceed with the program for the General Symposium on Tantalum to be held in the Spring of 1978 at Rothenburg ob der Tauber, West Germany.

Mr. Enno Muller, the official Thailand Smelting and Refining Co. representative, had submitted his resignation as a member of the Executive Committee. The Assembly expressed gratitude to Mr. Muller for his contributions. The election of a new Executive Committee for 1977-1978 was held. The officers will be:

President - Mr. Paul Leynen
Mr. Herman Becker-Fluegel
Mr. Reinhard Deil

Mr. Deil is the official representative of Gesellschaft für Elektrometallurgie mbH.

The presentation by Mr. David E. Maguire, General Manager of the Components Department of Union Carbide Corporation, covered the cyclical nature of the economy demonstrating the regularity of such cycles independent of the influence of political and governmental-action factors. Recognition of the three basic economic cycles makes it possible to accurately forecast the timing of recessionary and growth periods of the economy. A condensation of Mr. Maguire's presentation will be published in « Bulletin » No. 11.

The Eighth General Assembly will be convened at 10.00 a.m. on Tuesday, 11 October 1977 in Brussels, Belgium. Specific details will be made available to members in advance of that meeting.

On the day previous to the General Assembly, thirty-six of the attendees visited the mine and mill of the Tantalum Mining Company of Canada at Bernic Lake, Manitoba. A well planned and executed tour provided the visitors with a thorough inspection of the world's largest single source of tantalite.

Tantalite Deposit in Egypt

During 1971, the press disclosed the existence of a large tantalite deposit in Egypt. Since that time, little information has been publicly revealed about this resource. In view of the current and expected need for more tantalite resources, known data about the deposit has been reviewed with the purpose of evaluating the potential as a future source of tantalum.

The Nuweibi tantalum deposit was identified for the first time in March 1970 as a part of a detailed prospecting venture carried out jointly by geologists of the Soviet Union and Egypt. During the period from October 1970 to March 1971, a tantalum ore-bearing zone of 0.16 sq. km. was found in the upper reaches of Wadi el-Nabi el-Atshan in the Central Eastern Desert, 30 km. west of the Red Sea and 16 km. south of Abu Dabbal. Twenty-three bore holes were drilled at intervals of about 100 m. along parallel profiles 100 m apart. Topographic and geological surveying along with sampling was carried out.

The deposit is composed of Upper Proterzoic Metamorphosed Sedimentary-Volcanogenic formations. The tantalum mineralization is spatially and genetically associated with apogranite intrusions. The apogranite spreads over an area of 0.44 sq. km. in a lens-shaped body with a gentle dipping. The thickness of the apogranite body is 90-150 m. divided into three zones. The upper zone, averaging 32 m. in thickness, is the principal site of the tantalum mineralization. As governed by the minimum commercial contents of 0.017 % Ta₂O₅, the ore body appears as a bed-like body with an uneven thickness varying from 6.0 to 98.2 m. with an average of 35.0 m. and an overburden ratio of 0.947.

The ores are hard massive rocks with a volumetric weight of 2.16 tons per cubic meter and are very rigid with a thin impregnation fabric. The mineralization, however, is regular. On this basis the Ta₂O₅ content amounts to 0.619 lb./cu. yd., equivalent to 0.340 lb./ton. Thus the ore would be considered as being of poor to medium quality. The average ratio of Ta to Nb is 2:1.25. Four types of apogranite are identified in which the assay of Ta₂O₅ and Nb₂O₅ are as follows:

Type of Apogranite	Samples Analyzed	Ta ₂ O ₅ %	Nb ₂ O ₅ %	Ta:Nb
1	64	0.0156	0.0095	1:0.61
2	107	0.0151	0.0094	1:0.62
3	216	0.0157	0.0097	1:0.62
4	27	0.0085	0.0120	1:1.41

All four types range from 74 % to 76 % SiO₂, 14 % to 19 % Al₂O₃, with iron, CaO, and Na₂O being the other major constituents. Traces of tin, molybdenum, zirconium, etc., are all well below 50 ppm each.

T.I.C. SEVENTH GENERAL ASSEMBLY

On May 4, 1977 the Seventh General Assembly of the T.I.C. convened in Winnipeg, Manitoba, Canada. Forty-six members and guests were in attendance. In addition to discussion of business on hand, a presentation was made by Mr. D.E. Maguire, General Manager, Component Department, Union Carbide Corporation, « A Technical Approach to Economic Forecasting ».

The meeting was preceded on May 3 by a visit to the mining and milling operation of the Tantalum Mining Corporation of Canada at Bernic Lake in Manitoba.

The Eighth General Assembly will be held in Brussels, Belgium on Tuesday, 11 October 1977.

Within the limits of the 0.017 % Ta₂O₅, the reserves are estimated at 31.9 million tons providing 12,300,000 lb. Ta₂O₅ contained and 6,500,000 lb. Nb₂O₅. If the body is extended to include Ta₂O₅ content down to 0.0156 %, the estimated reserves are 82.2 million tons providing 28,000,000 lb. Ta₂O₅, 16,600,000 lb. Nb₂O₅.

At the end of 1975, a feasibility study on the exploitation of the Nuweibi deposit was under way. Laboratory samples from the four types of ore-bearing apogranites were collected for ore-dressing investigations in the Goredmet Research Institute in the U.S.S.R. and in the laboratory of the Geological Survey in Cairo. The results of these evaluations are unknown. Mining and technical conditions of exploitation of the deposit, however, are considered favorable and do allow open-cast mining. When final results of laboratory tests are known, the commercial value of the deposit can be determined.

Some indication of the commercial feasibility of exploitation might be obtained on a hypothetical basis. If an operation comparable to Bernic Lake were set up mining 650 to 700 tons of rock per day, only 33,000 lb. Ta₂O₅ per year would be produced (compared to 380,000 lb. at Bernic Lake). Even at prices of \$20.00 per lb. of contained Ta₂O₅ the resultant annual sales income of \$660,000 hardly seems adequate to support the investment which would be required to provide infrastructure, mining operations, and a concentration plant.

The Chemical Processing of Tantalum Source Material

The source materials from which tantalum is extracted, whether natural ore concentrates or tin slags, are combinations of silica, alumina, titania, and calcium compounds. Many other elements are present in varying amounts dependent on the source. Commercial tantalites will range from 20% to 65% Ta_2O_5 , tin slags from below 2% to as high as 35% Ta_2O_5 . Generally, niobium oxide is also contained, varying from less than 5% in microlite and ores from Bernic Lake to as high as 65% in the columbites from Nigeria. Because of this great diversity of source material, each major processor is faced with a continually changing mixture as no single source is sufficient to provide its total needs. For economic operation, a process to extract the tantalum and niobium must be equally applicable to all types of source materials.

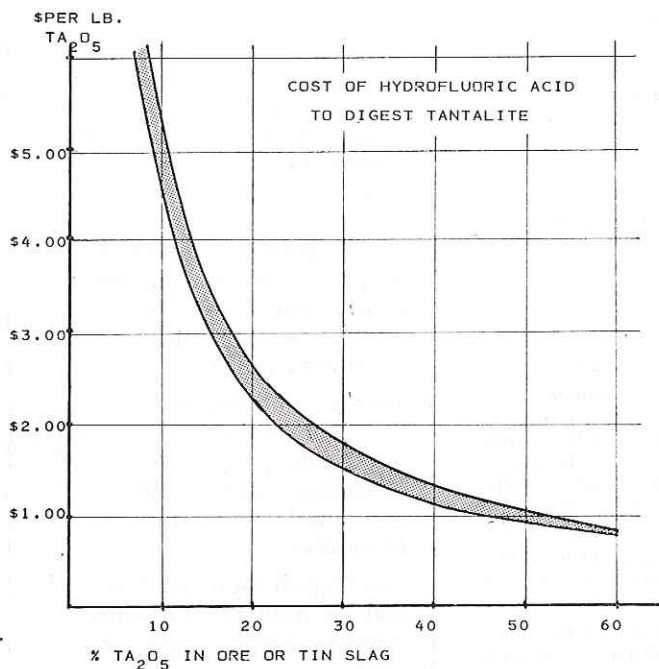

Columbite-tantalite ores present a serious processing problem in the separation and purification of the niobium and tantalum. The two metals, coexisting in most ores and tin slags, have a very similar chemistry and there are few chemical reactions which differentiate between them. Although several extraction processes have been developed during the past fifty years, the processing industry has universally accepted one process based on digestion of the ore with hydrofluoric acid (HF) and extraction with methyl isobutyl ketone (MIBK). The flow chart shows that there are four basic steps: digestion, extraction, separation, and salt preparation.

Digestion — Ores and slags are digested in 70% HF. A plain steel tank is generally used which might be small enough to handle only 300 kg. of ore or, in some cases, large enough to handle 1500 to 1800 kg. The tank has an agitator and a bottom drain. HF is charged into the tank and then the ore is added at a controlled rate. The dissolving process generates heat which must be removed by water in a jacket around the tank as 70% HF begins to fume, losing strength, if the temperature exceeds about 85°C. To avoid such, some digesters are totally closed so that internal pressure can build up, allowing the reaction to be carried out at higher temperatures without loss of acid strength.

The dissolving process is slow. Batch time will require from 15 to 20 hours. Agitation is continuous. Up to 98% of the niobium and tantalum is dissolved, forming fluoniobic acid (H_2NbF_7) and fluotantallic acid (H_2TaF_7). Much of the silica, alumina, etc. is not dissolved and remains as a solid residue. Iron and titanium will go into solution, however, and means to remove them must be effected.

Extraction — The ability to extract the tantalum and columbium values from the acid solution depends on the fact that the fluoniobic and fluotantallic acids are soluble in certain organic solvents which are water-immiscible. Of possible organic compounds, methyl isobutyl ketone (MIBK) is the most effective as it will dissolve 93% to 95% of the acids. A small amount of the iron, titanium, and other fluorides also dissolve.

After the batch from the digestion tank has been drained into an extraction tank, the MIBK is added. The charge is agitated continuously for several hours to provide thorough mixing. When agitation is stopped, the MIBK gradually rises to the top as it is considerably lighter than the aqueous acid solution. The MIBK containing the fluoniobic and fluotantallic acids is then decanted and piped to a holding tank. The residue, consisting mainly of insoluble fluorides with a little niobium and tantalum, is filtered to remove excess ketone and is then discarded.

Purification and Separation — The ability to eliminate impurities and separate the fluoniobic acid from the fluotantallic acid results from two facts:

- Fluotantallic acid is more soluble in MIBK than fluoniobic acid, and both are more soluble than impurities.
- The solubility of tantalum, niobium, and impurities in both MIBK and water differ from each other at various acid concentrations.

The process is generally continuous. It can be carried out in a series of small tanks or in mixer-settler boxes consisting of a number of cells separated by baffles. In either case, alternate stages are equipped with stirrers to effect mixing, and the intermediate stages are provided for settling and separation. The system works on the basis of countercurrent extraction. Two immiscible solvents of different density are moved in opposite directions with intermittent mixing and settling. The lighter solvent is MIBK and the heavier one is an aqueous solution (raffinate).

The process is best described on the basis of the mixer-settler box system. This is comprised of four separate boxes, as shown in the flow-chart.

- **Box 1:** Fresh MIBK is introduced at one end and an aqueous sulfuric acid solution at the other. The fresh MIBK first extracts the slight amount of niobium and tantalum picked up in the aqueous raffinate and is then added to the feed solution introduced after several sections. As the organic solution moves toward the outlet end, it is alternately mixed with and separated from the aqueous acid solution, the acidity of which has been established to extract all of the impurities from the organic solution. The aqueous raffinate including the impurities is discarded. The organic solution containing only fluoniobic and fluotantallic acids is piped to the second box.
- **Box 2:** Decreasing the acidity of the solution of fluoniobic and fluotantallic acid by a certain amount converts the fluoniobic acid into a fluorine compound of niobium which is preferentially soluble in water. By careful control of acidity, substantially all of the fluoniobic acid is converted and dissolved into the aqueous solution. The separation is so effective that raffinate will contain as high as 99.9% of the niobium and as little as 0.05% of the tantalum. The organic solution still containing the tantalum is piped to the third box while the raffinate containing the niobium is piped to the fourth box.
- **Box 3:** Since it is necessary that the fluotantallic acid be in water solution for further processing, this box merely accomplishes such. By introducing water, the acidity is sufficiently lowered that substantially all of fluotantallic acid is rendered preferentially soluble in the aqueous scrub solution. The resulting raffinate contains 99.9+% of the tantalum. The stripped organic is recycled for the extraction step of a subsequent digestion batch.
- **Box 4:** The raffinate from Box 2 containing the niobium also contains a small amount of tantalum. This box uses fresh MIBK to extract that tantalum from the raffinate so that the niobium solution will be pure.

Preparation of Potassium Tantalum Fluoride (K_2TaF_7) — For reduction to metal, potassium tantalum fluoride is used. The raffinate (from Box 3) containing the fluotantallic acid is pumped into a large, plastic tank. The additions of potassium fluoride solution results in a reaction and precipitation of white, needlelike crystals of the potassium tantalum fluoride. When the reaction is complete, the mother liquor is siphoned off and the crystals are dropped through the bottom of the tank into a centrifuge. The crystals are spin-dried and washed, and then placed in a stainless steel, steam-jacketed, rotary dryer. When dry, the salt can be stored in drums until needed for reduction.

Preparation of Niobium-Oxide — The high purity niobium raffinate (from Box 4) is pumped into large plastic tanks. Anhydrous ammonia is added to convert the niobium to hydrated niobium pentoxide ($Nb_2O_5 \cdot H_2O$), a white, amorphous precipitate. The mo-

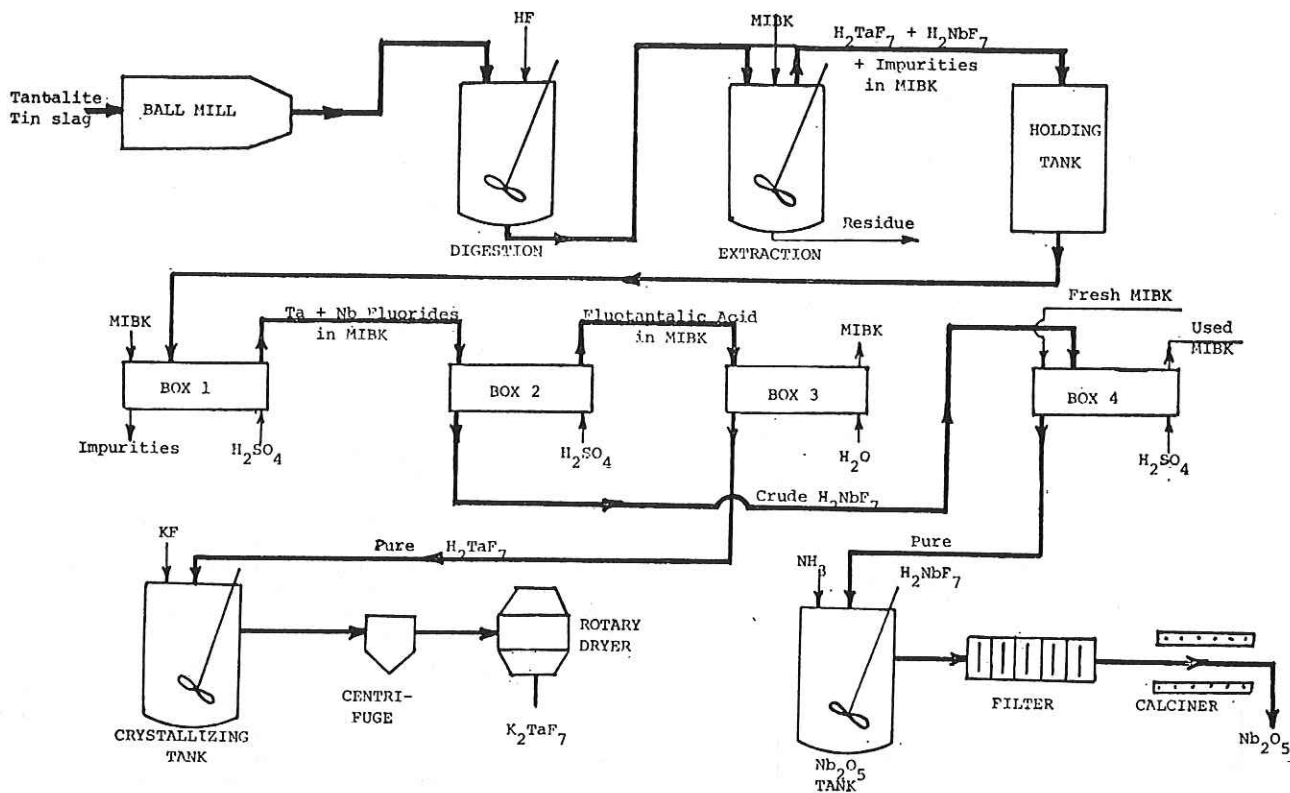

ther liquor is pumped off and the precipitate washed to remove fluorides. After filtering, the resulting cake is calcined at 875° to 975 °C, producing high purity niobium oxide.

SOME ECONOMIC CONSIDERATIONS

The cost of processing columbite-tantalites and tin slags through the chemical plant is variable with the quality of the feed stock, causing differences in the market value of various types of ores and slags. Once the potassium tantalum fluoride has been produced, the costs for further processing are the same, irrespective of the raw material source.

The major element of chemical processing cost is the cost of the HF used. The quantity required is from 1.25 lb. to 1.5 lb. HF per lb. ore. The Ta₂O₅ content of the ore has little effect on this ratio. Thus 10 lb. of slag containing 10% Ta₂O₅ requires 12.5 to 15 lb. HF. But an ore containing 50% Ta₂O₅ will require only 2.5 lb. to 3 lb. HF. At present cost of about \$0.35 per lb. for

HF, the cost differential for the acid will range from \$3.50 to \$4.20 per lb. Ta₂O₅ fed. The cost of HF alone as a function of ore quality is demonstrated on the graph.

There are other cost elements which vary with the quality of the feed stock. The volume of ore which must be stored and handled varies with the tantalum content. The handling cost is therefore about four times as great for the 12.5% slag as it is for the 50% concentrate. Acid neutralization cost is greater for low-grade materials. These factors, as well as others which must be considered, probably affect the total cost of processing to the same degree as the HF cost. Experience has shown that the cost differential between two grades of feed stock is roughly double the cost of the HF. Thus, for the example used above, it would be expected that the 10% slag would have a market value at least \$8.00 per lb. lower than the market value of the 50% concentrate. In practice, another factor to be considered is the niobium content which will affect the market value. An ore containing a high percentage of niobium is worth more than ore containing no niobium.

Explosion-Welded Tantalum in Chemical Plant Equipment

The material for the following article is based on an explosion-clad process developed by W.C. Heraeus GmbH of Hanau, West Germany for use in their manufacture of chemical equipment.

The materials selected for use in chemical plant equipment depend on the type of reaction which will take place in the equipment. For the production of important base chemicals to obtain intermediate and final products, extreme conditions often exist, processing taking place at high temperatures and with very corrosive solutions. In order to provide adequate economic life, the equipment has been historically lined with precious metals, coated with enamel, or made of glass. Due to the increasing demand for larger plants, cost saving methods have been developed to meet specific requirements.

Tantalum is a material which provides excellent corrosion resistance combined with good mechanical strength, high thermal conductivity, and good weldability, especially in oxidizing media at high temperatures. As a result of its relatively high price, lined tanks and piping has been used, except in laboratory plants and small components for which solid construction has been used. Because of the disadvantages of historically used loose liners under pressure conditions, a composite material of a thin clad of tantalum on a strong structural material is desirable. To provide a practical method of cladding, explosion-welded composite materials have been developed.

Explosion-welding can provide a complete metallurgical bond between the component materials of the clad composite, thus eliminating such problems as differential thermal expansion. The tantalum sheet to be clad to the metal base plate is coated with explosive and fitted with an igniter as shown in Fig. 1.

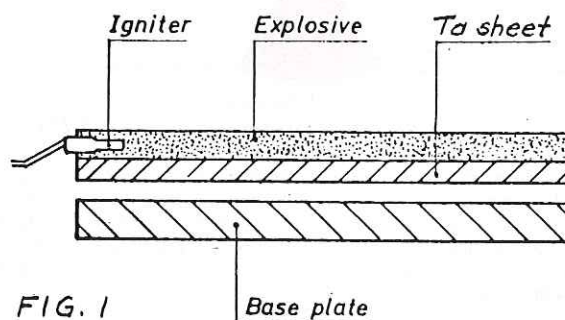
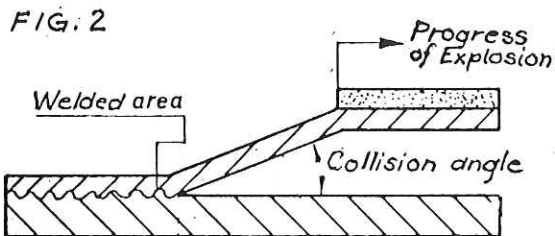

FIG. 1 Base plate

Upon detonation, the explosion occurs progressively across the sheet at a very high speed. The explosion force accelerates the tantalum sheet toward the base plate at a very high speed with tremendous force, causing it to progressively impact the base plate at a defined collision angle (Fig. 2).



The reaction is so rapid that very little heat is generated and, although welding is effected, the materials never get hot enough to create significant difference in thermal expansion between the two metals. Thus the brittle intermetallic alloy formed in the weld zone does not fracture after cooling.

In order to clad with very thin tantalum sheet, a combined method of explosion-welding and mechanical deformation has been developed. As shown in Figure 3, greatly enlarged, a thin layer of an intermediate softer steel is interposed between the tantalum sheet and the heavy base-metal.

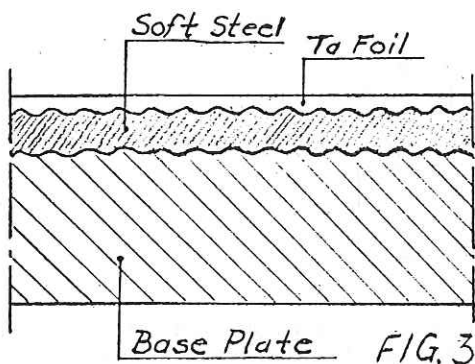

To clad with tantalum as light as 0.15 mm (0.006 in.), an interface of about 1 mm (0.040 in.) thickness would be used. When fusion welding is required to join composite plates, a copper interface is often used to disperse by conduction the heat of welding.

Fusion welding of clad plates requires special preparation. The welding of the thin layer of tantalum cannot be effected successfully. The high fusion temperature of tantalum prevents proper control of the weld and local areas of both the tantalum and steel are melted away. Areas of brittle and less corrosion resistant intermetallic places are also formed. Therefore, to be able to fusion weld joints between clad plates, the tantalum is ground or machined off for an area on each side of the weld bead equal in width to at least the thickness of the basemetal plate. Then, after the fusion weld is complete, a tantalum strip about 0.2 mm (0.008 in.) thick, is applied to the steel weld bead and its adjacent areas of the tantalum layer by explosion-cladding (Figure 4).

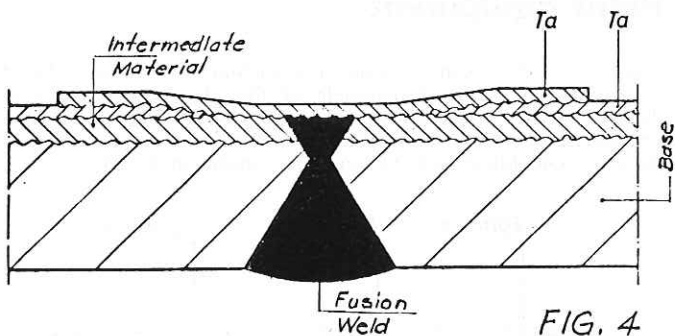

The cladding of pressure tubes on the inside surface is accomplished in the same fashion as cladding a flat plate. A thin wall tantalum tube coated on the inside with explosive is inserted within the slightly larger base-metal pipe. When the explosive is detonated, the tantalum tube is welded to the inside of the pipe as shown in Figure 5.

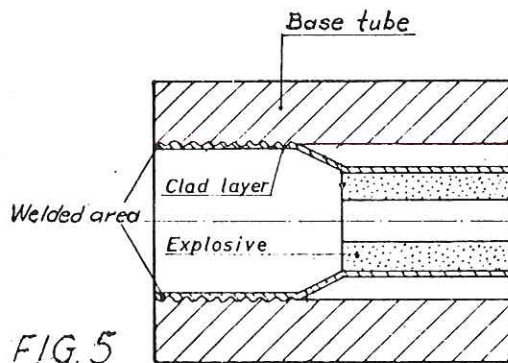

To join lengths of pressure tube or to form large pipe from pre-clad plate, the fusion welds required are made exactly as the fusion-welded joint previously described. Pressure tubes have been made as large as 300 mm (11.8 in.) diameter by 3 meters (9.84 feet) which operate at pressures of 4 bar (4.052 kg/sq.cm.) at a temperature of 250 °C. The base plate was 6 mm (0.236 in.) thick stainless steel clad with tantalum 1 mm. (0.039 in.) thick with an intermediate 1 mm. copper layer. The fusion weld was clad with a tantalum collar 1.2 mm. thick. The helium leak test of the complete pressure tube gave a leak rate of less than one ten-thousandth Torr per second.

The explosion welding process has extended the use of tantalum particularly in chemical processing equipment. The economical use of thin layers on strong substrates has made it possible to use the advantages of tantalum without the very high cost which would result if solid tantalum construction was used. In addition, the metallic composite provides much better heat transfer, reducing the energy required for heating chemical media to effect reactions. Thus the explosion welded process is an important step forward in the application of more tantalum as a structural material.

T.I.C. MEMBERSHIP

During the Seventh General Assembly on 4 May 1977, the following companies were elected members of the T.I.C.

BOC, Ltd.

Metals Division
Hammersmith House
London W69 VDX - England

Fansteel Inc.

Metal Division
No. 1 Tantalum Place
North Chicago, Ill. 60064 - U.S.A.

Hermann C. Starck Berlin

Postfach 7712
4 Dusseldorf 1 - West Germany

Mitsui Mining & Smelting Co., Ltd.

2-Chome, Nihonbashi-Muromachi
Chuo-Ku
Tokyo - Japan

S.A. Minerals Ltd., Part.

P. O. Box 31
Phuket - Thailand

Siemens A.G.

Werk Kondensatoren
Postfach 1840
D-7920 Heidenheim - West Germany

Standard Telephones & Cables Ltd.

I.T.T. Component Group Europe
Capacitor Division
Brixham Road
Paignton, Devon TQ47 BE - England